

---

**ABSTRACT**

For finishing area of MMSM department of VSP, The 5/2 CELLAR HYDRAULIC SYSTEM is having two units (LHS and RHS) separating pressurized oil of 100 bar to all hydraulic operated equipments in both sections (LHS and RHS) separately from batching to finishing area.

**KEYWORDS:** Steels, Hydraulics.

---

**INTRODUCTION**

For finishing area of MMSM department of VSP, The 5/2 CELLAR HYDRAULIC SYSTEM is having two units (LHS and RHS) separating pressurized oil of 100 bar to all hydraulic operated equipments in both sections (LHS and RHS) separately from batching to finishing area.

Both LHS and RHS hydraulic systems are totally same and each having lower tank of 25-m<sup>3</sup> capacity. From where hydraulic oil feeds to the upper tank by centrifugal pump which feeds 500t/min through filter and cooler (when necessary). From upper tank (3600\*21t) hydraulic oil feeds by constant flow axial piston pump to the control racks through safety control valves (outlet valves) and accumulator. From control racks different equipments are operated according to the operation requirement through solenoid valves.

Each hydraulic system consists of 6 numbers of cooling and filtering pumps. Out of then three numbers is one side and other three are on another side installed on lower tank. For normal working of the system, one or two cooling and filtering pump is running for each side (out of 6 no's pumps only two are running). Remaining pumps are stand by in normal working of the system only two pumps are having sufficient capacity to supply hydraulic oil to the upper tank. Due to continuous operation of the system hydraulic oil is getting heated. So after pumping from lower tank, oil passes through cooler, soon the oil temperature is more than normal temperature (45°C). If oil temperature is normal, then oil by passes the cooler and filter directly goes to the upper tank. This by passing and passing through cooler is controlled by solenoid valve cooler is indirect water cooling type heat exchanger. For this we are supplying water from pump house. For supply of water to the cooler is also controlling by solenoid valve, which supply water, when oil gets heated

**HYDRAULIC OIL SYSTEMS**



### Hydraulic Oil System

Hydraulic oil feeds from upper tank to the outlet control valve (p valve) by constant flow axial piston pump at high pressure (max.pr.250bar,300l/min) total ten numbers of axial piston pumps are installed on the lower tank, just below of lower tank. Out of ten numbers pump only two pumps required for normal working pressure. Remains are for standby. The outlet valves (two numbers) control the high pressure and supplies the hydraulic oil at 100bar pressure. Outlet valve consists pressure switches, pressure relieve valve, solenoid valves, cartridge valves, key operated valves, shutoff valves and connected with twenty numbers (ten numbers for each p valve) accumulators p valves supplies oil at 100bar, (which is adjusted by PVR) to the control racks, from where different equipments are operated by solenoid valves. After operating the equipment hydraulic oil goes back to the lower tank through return line (T line) filters, where dust containments are separated and dust from oil goes to the lower tank. Total four holes of return filter housings are fitted in one system out of four holes two holes are using at a time.

### PRINCIPLE OF HYDRAULICS

#### Hydraulics is a Greek word

- 'Hyder' means water.
- 'aulos' means pump.

Hydraulics can be considered by the application of the principles of hydrostatic and hydrodynamic as the study of fluids in motion.

### PASCAL'S LAW

Pressure applied on a confined fluid will be transmitted undiminished in all directions and acts with equal fore on equal areas and at right angles to them.

### ADVANTAGES OF HYDRAULICS: -

- For large distance force (or) torque
- Power to weight ratio 175th of electrical equipment
- High Response
- No slippage
- Mechanically Stiff
- Self Lubricating
- No wear and rusting
- Self cushioning

### DIS-ADVANTAGES:-

- Initial cost is high
- Maintenance cost is high
- Fault diagnosis is difficult
- Housekeeping is difficult
- Fire Hazard is more due to leakages
- Dust catching & hence contamination

### CONSERVATION OF ENERGY:

This states that "energy can neither be created nor destroyed "it can only be converted from one form to the other.

### HYDRAULIC FLUID:

Most commonly used hydraulic fluid is mineral oil. To improve its property to suit that requirement, some additives will be added. Mineral oils have high lubricity, good resistance to oxidation and dissipate heat quickly, but main disadvantage with this is it has low fire point.

**HYDRAULIC OIL (HLP 46) PROPERTIES**

SI.No	Characteristics	
1.	Appearance	C & B Clear & Bright
2.	Kinematic Viscosity CST	
	At 40°C	46.8 cent! strokes
	At 100°C	6.75 centi strokes
3.	Viscosity Index	97
4.	TAN/mig koh/g Total Acid Content	0.46
5.	Specific Gravity	0.85
6.	Power point	-15°C
7.	Flash point	238°C
8.	Rust Test with synthetic sea water D-665	Pass
9.	Air release value 50°C,Min	8
10.	Vickers vane pump test	Pass













*TAB:The properties of (HLP 46) hydraulic oil***TECHNICAL DATA****APPLICATION:**



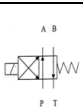

The hydraulic drive of the finishing section is to supply pressure liquid for hydraulic consumers- hydraulic rotating motors and hydraulic cylinders of machine equipment of the finishing shops.

**TECHNICAL PARAMETERS**

Main dimension 18747mm, Length 2860mm, Height 3380mm, Weight 44000kg, working pressur 10mpa, Max. Working pressure 12.5mpa, Number of accumulators 20, Effective volume of accumulators 100 dm<sup>3</sup>, when 10% pressure drop Accumulator filling pressure 9.5mpa, Filling medium nitrogen n2-purity 98.6%, Number of hydraulic pumps for 10 mpa working/standby 8/2, Supplied volume of 1 hydraulic pump 360 dm<sup>3</sup> /min, axial piston ones with Constant pressure control, Supplied volume of filtering hydraulic pump 450 dm<sup>3</sup> /min, Type of hydraulic pump centrifugal two-stage one Oil filtering for intake 100%-10µm, Oil filtering in return piping 100%-25µm, and Oil volume in tank Max. 21000 dm<sup>3</sup>/ min 9050 dm<sup>3</sup>, Working liquid hydraulic oil as per ISO VG 68, Supplied volume of pump-out hydraulic pump 115 dm<sup>3</sup>/min, Type of hydraulic pump gear Supplied volume of pump-over 115dm<sup>3</sup>/min hydraulic pump, Type of hydraulic pump gear one Electrical motor input of 65kw main hydraulic pumps, Electrical motor input of 7.5kw filtering hydraulic pump, Electrical motor input of pump-over 3kw hydraulic pump, Electrical motor input of pump-out hydraulic pump Total drive input 1002kw Voltage 415v, 50htz., Control voltage switchboards 45v.dc ,Cooling input of one cooler 32.6kw water 35'c, oil 50'c) Cooling water consumption mx.480dm<sup>3</sup>/min, Noisiness 95db

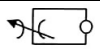
**HYDRAULIC SYMBOLS**

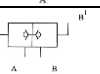
1. Hydraulic Pump	
2. Check Valve	
3. Measuring Connector	
4. Pressure Relief Valve	
5. Hydraulic Filter	
6. Temperature Signal Switch	
7. Heating Coil	
8. Shut off Valve	
9. Catridge Valve	
10. Pressure Switch	
11. Globe Valve	
12. Hydraulic Control Valve, (Electrical Control)	
a) 4/2 One side electromagnetic control	
b) 4/2 both side electrical with position lock pulse control	

1. Single Throttle / Check Valve	
2. Water Cooler	
3. Non – Return Valve / Check Valve	
4. Hydraulic Lock	
5. Hydraulic Accumulator	

**HYDRAULIC ACCUMALATORS:**

A hydraulic accumulator serves to take into store a volume of fluid under pressure and to release it again, as required. The pressure can carry out many takes in a hydraulic circuit.

**P.C.V. (Pressure Control Valve):**

Pressure control valves serve to influence pressure in a unit or in a part of unit. The valves can be sub -divided into 3 groups according to function.

- Pressure relief valves
- Pressure sequence valves
- Pressure reducing valves

**SHUT OFF VALVES:**

In a hydraulic system shut off valves serve to check flow in a preferred direction and allow the flow in the opposite direction, they designated as check valves. The shut off valves are designed as poppet valves and therefore provide leak free closure.

**PRESSURE SWITCH:**

Hydro electric pressure switches serve to switch an electrical circuit ON and OFF, related to pressure. The pressure switch can be used as control unit or also for monitoring purpose i.e. by means of usual (lamp) or acoustic belly indicator.

**CATRIDGE VALVE:**

2/2catridge valves often called "logic elements" comprise a cartridge assembly with a cover and control bores. Switching position is dependant only on the pressure condition at this element.

**HYDRAULIC FILTER:**

Filter is a device whose primary function is retention by same porous medium of insoluble impurity from the fluid.

**D.C.V (DIRECTIONAL CONTROL VALVES):**

The purpose of a D.C valve is to direct the flow of oil in the direction we need .

**CHECK VALVE (NPV):**

It is nothing but a one way direction valve Check valve permits free flow in one direction and blocks flow in the other.

**PRESSURE RELIEF VALVE:**

It is the common type of pressure control which is used to provide against over loading of hydraulic circuit components.

**SOLENOID OPERATED D.C. VALVE:**

A solenoid is a electro mechanical device that converts electrical energy into linear mechanical motion. Solenoid operated 2-way and 4-way valves are used where it is desirable to control the direction of fluid by an electrical signal.

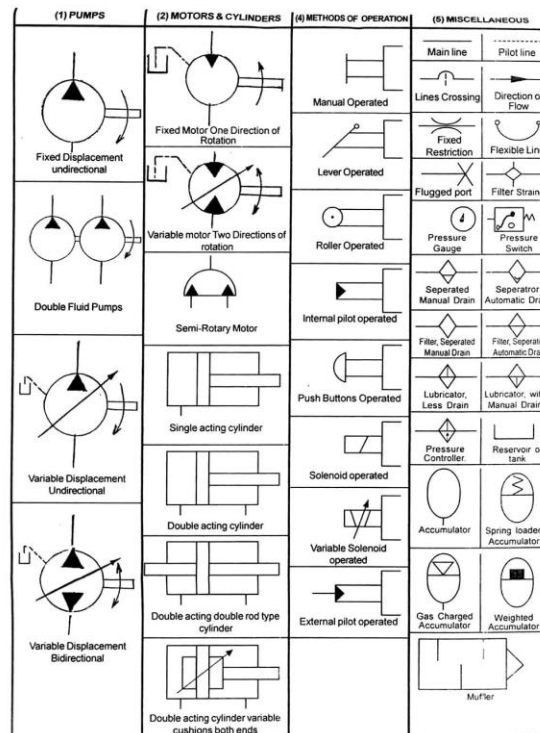
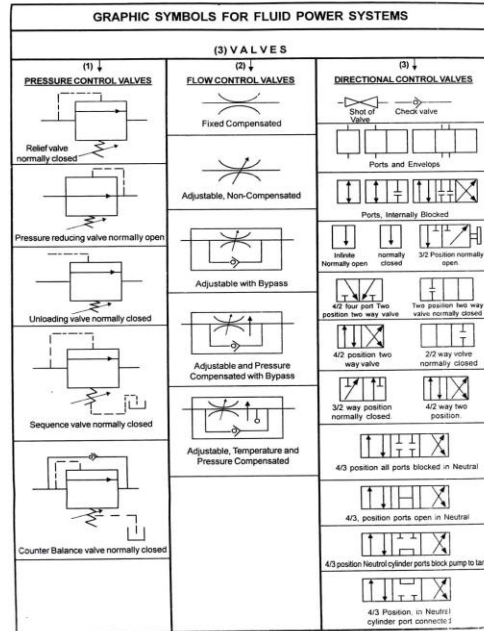

**FIG VALVES SYMBOLS**

**HYDRAULIC OIL COOLING SYSTEM:**

Water coming directly from pump house is passing through water filter and shutoff valve. This water supply for cooler (indirect water cooling type and having cooling are 3m<sup>2</sup> work pressure of water-6 bar) is controlled by solenoid valve. After cooling the hydraulic oil water goes back to the pump house.

In this system we are bypassing the oil when it is in normal temperature (45°C). When more than normal temperature oil allowed to flow through the cooler. For this system we have one no. one way double port solenoid valve C-40, which is de-energized at normal temperature and allowed oil flow directly to the upper tank. But when oil gets heated and temperature increases more than normal temperature, solenoid valve (40 gets energized, stops the bypass way and it allows the oil to flow through cooler. At the same time water supply control solenoid valve C 34(1/2 valve) gets energized and supplies water to the cooler.

When oil gets cooled, the solenoid valves C-40 and C-34 automatically de-energized. C-40 allows the oil directly to the upper tank and C-34 stops the water supply for cooler. These solenoid valves are operated by temperature sensor (switch), which gets ON when oil temperature is more than normal temperature and gets OFF, when oil is in normal temperature.

### HYDRAULIC OIL FEEDING SYSTEM:

#### (From lower tank to upper tank)

From lower tank to upper tank oil feeds by centrifugal pump of having maximum discharge of 500 l/min. At 2 bar pressure, through filter of 2 M and cooler. Cooler is indirect water cooling type and having cooling are 3 m<sup>2</sup>, work pressure of water 6 bar and work pressure of oil 10 bar. When oil temperature is normal (up to 45°C) cooler bypasses and oil directly feeds to the upper tank. This bypassing system is controlled by solenoid valve, which is de-energized at normal temperature of oil and directly feeds the oil to the upper tank. But when oil temperature is more than 45°C (normal temperature) solenoid valve gets energized and stops the bypassing way, allows the oil flow through cooler. In this system there is two no's of hydraulic oil pressure checking points. One is before and another is after filter. By which we can measure the oil pressure before and after the filter. By comparing these pressures we can know about filter position. Total 6 nos. of cooling and filtering pump installed in each system. Out of 6 nos. only 2 nos. are required to feed oil from lower tank to upper tank. Rests are for stand by.

#### (From upper tank to control racks through outlet control valve)

From upper tank to hydraulic equipments control racks, oil feeds with the help of constant flow axial piston pump having maximum discharge 300 l/min and maximum

### CENTRIFUGING SYSTEM :

Radially outward force on a body in a uniform circular motion observed in a rotating frame of reference is called Centrifugal Force.

- It acts normally on the particle executing uniform circular motion.
- It is directed radially away from the centre of the circle.
- It makes a body fly away from the center of the circle.
- It comes into play in a rotating frame of reference.

$$F = mVr = m r\omega^2$$

- It is a fictitious force in an initial frame of reference.
- It cannot be associated with an agent.
- In a uniform circular motion its magnitude is constant and equal to that of centripetal force.
- This force depends upon the mass of the body.
- Hence the bodies of higher mass rotate on a circle of higher radius.
- Application of centrifugal: Connecting a Satellite into an orbit.

### CENTRIFUGE:

A centrifuge is a machine which is used to separate particles of higher mass from those of lower mass in a given mixture.

#### Working :-

When a mixture (milk) is poured in to a cylindrical vessel of centrifuge and rotated with high speed the particles of higher mass (Skimmed milk) are thrown away from the centre due to greater centrifugal force and particles of lower mass (Cream Particles) get accumulated at the centre near the axle. When a vehicle moves on a curved park the



necessary centripetal force is provided by the frictional force between the wheels and the road. If the frictional force is not sufficient the vehicle skids.

In MMSM (finishing) this centrifuging machine is playing a vital role in separating the foreign particles from collected oil as well as from the oil of the system on line. After the machine attains substantial speed it is primed with water then suction valve Cle-CLnfc4 is opened to allow oil to be cleaned into the separation then outlet is also opened to desired tank into which classified oil is to be collected. If the machine is stopped due to some reason or the other the circular speed of the bowl is not there, then inlet valve should be closed failing of which inlet line flow connects directly to grain line due to absence of centrifugal force.

#### WORKING SYSTEM OF OUTLET VALVE :

For normal running of hydraulic station:

- C-60 shut off valve will remain closed condition.
- C-48 & C-46 key operated valve will remain open position (not\connected to tank).
- C-46 is in obeyed position means accumulators will be not connected to tank. Excess pressure developed by pump will be relieved by relief valve C-54. which is adjusted at 100bar with the help of PRV C-62. When C-54 closed the tank line, and key operated valve C-48 is open condition, (close position mean connected to tank) oil goes to accumulators and pressure switch C-52. which gives the signal if pressure is normal. For going oil, to the control racks YVH 1A & YVH 2A are to be engaged, then C-52 puppet valve will open and oil will go to the control racks. C-57 pressure switch gives OK signal if out let pressure is normal. If pressure is not normal (due to leakage or pump pressure) then YVH 1A & YVH 2B will automatically get de- energized with in specific time (1 min).
- C-60 Shut off valve is given for quick draining of pressure line if required.
- C-32 Solenoid valve is given for automatic draining of pressure line, if system is made off or system gets off due to pressure minimum fault.
- C-62 Relief valve is given for adjusting the pressure.
- C-48 Key operated valve given for drainage the accumulator is required.
- C-151 Check valve mounted on T line for adjusting back pressure in T-line.

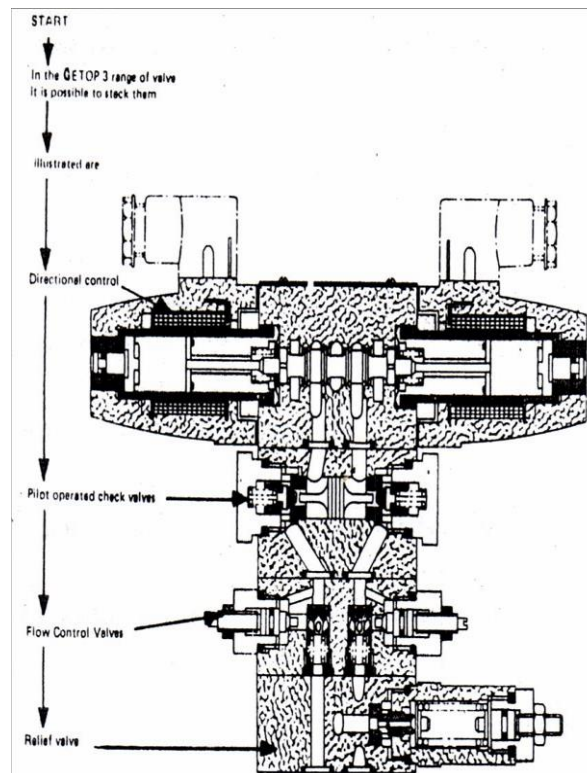

#### TROUBLE SHOOTING CHART:

<http://www.ijesrt.com>

© International Journal of Engineering Sciences & Research Technology



Trouble shooting for the 5/2 hydraulic station is tripping due to signaling panel showing.

1. Upper tank oil level minimum.
2. Lower tank oil level minimum.
3. Maximum oil temperature.
4. Outlet pressure minimum.
5. Electrical fault.

**UPPER TANK OIL LEVEL MINIMUM:**

Possible cause	Action to be taken
Filtering and cooling pump tripped due to some electrical reason.	To be informed to electrical
b) Filter clogged.	Filter to be changed.
c) due to fault in level indicator switch (If oil level is correct).	To be informed to instrumentation to Check the level switch.
d) Pump not discharging due to air locked.	Air locked to be removed.
e) Centrifugal pumps tripped one to lower To lower tank level minimum. Check Re filter.	Fill the oil after as Pertaining no leakage

**LOWER TANK OIL LEVEL MINIMUM:**

Possible cause	Action to be taken
Due to really hydraulic oil is less in the System	oil to be filtered
Return line filter clogged	Filter to be changed for cleaned.
Due to any leakages in the pipe line.	To be checked for leakage
Due to level switch fault (If oil level is more than minimum)	To be informed to instrumentation Section

**MAXIMUM OIL TEMPERATURE:**

Possible cause	Action to be taken
water cooler's not functioning due To solenoid valve C-40	To be checked for spool movement.
	To be checked for electrical supply
water cooler's not working due to water supply	* Check for solenoid valve C-34. no
	* Check for shut off valve
	* Check for water filter.

**OUTLET PRESSURE MINIMUM:**

Main pumps, filtering and cooling pumps (i.e. system) are running but on control panel signal is coming minimum pressure.

Possible cause	Action to be taken

Out let valve pressure switches Problem	To be checked by elect by Instrumentation.
Pumps are not building pressure	To be made on standby pumps

**OUTLET VALVE PROBLEM:**

Possible cause	Action to be taken
<b>Shutoff valve C-60 in open position</b>	To be closed
<b>Valve YVH 2B in disengaged position (means connected to tank),</b>	To be checked for spool movement and for electrical supply
If spool strucked in disengaged position	To be checked
If a spool movement good	To be checked for electrical
<b>Solenoid valve YVH1A disengaged position</b> (Poppet valve C-52 is closed position)	To be checked for spool movement
If spool strucked in disengaged position	Valve to be replaced
If a spool movement good	To be checked for electrical
<b>C-46 key operated valve</b> If should be in normal (open) position)	To be checked for open Or closed Position
If C-46 key operated valve pressed	To be kept in normal position
(closed) position	To be checked for spool movement
If C - 46 is open position	Valve to be replaced
If spool got strucked	To be checked for locking mechanism
If spool movement is good	
<b>C-48 key operated valve</b> (If should be unpressed position).	To be checked for open or closed position
If C-48 pressed (closed) position	To be kept in unpressed position
If C-48 open position	To be checked spool movement
If spool got strucked	Valve to be replaced
If spool movement is good	To be checked for locking mechanism
<b>PRV C-62 pressure adjustment not good</b>	To be checked for pressure adjustment

**SEPARATOR:**

**Principle:** Centrifuging is the process of separating particles of higher mass from those of lower mass in a liquid substance. When a liquid substance like oil is poured into a cylindrical vessel of the centrifuge and rotated with higher speed. The particles of higher mass are thrown away from the centre one to greater centrifugal force. A typical centrifuging machine is shown below.

In MMSM (finishing) this centrifuging machine is playing a vital role in separating the foreign particles from collected oil as well as from the oil of the system on line. After the machine attains substantial speed it is primed with water then suction valve is opened to allow oil to be classified into the separation then outlet is also opened to desired tank into which cleaned oil is to be collected. If the machine is stopped due to some reason or

the other the circular speed of the bowl is not there, then inlet valve should be closed failing of which inlet line flow connects directly to grain line due to absence of centrifugal force.

#### Main parts of separator

1. Pumps.
2. Motors.
3. Bowl.
4. Centrifugal Clutch.

#### PUMPS:

The following pumps can be attached to the separator.

1. **Single gear pump:** For clean oil discharge or for dirty oil feed.
2. **Double gear pump:** For simultaneous clean oil discharge and dirty oil feed.

All bearings and gear parts are splash lubricated from a control oil bath. As lubricating oil use only high grade solvent refined mineral oils designated

#### DRIVE MOTORS:

- When selecting DC motors, speed/load characteristics must be taken into account.
- Shunt wound or compound wound motors may only be used.

#### BOWL:

- The bowl speed depends on the densities of the heavy liquid phase, and of the separated solids.
- Majority cases bowl speed will have to be reduced by exchanging the gear parts.
- For densities up to  $1.1 \text{ Kg/m}^3$  the bowl speed of the separator  
On model OTA 18:7000 rpm  
On model OTA 30:6500 rpm
- For densities higher than  $1.1 \text{ Kg/m}^3$  the gear must be changed to reduce the bowl speed .
- The starting time of the bowl is 5-8min
- The bowl can be used for purification, i.e. separation of oil –water mixtures, or for clarification, i.e. separation of solids from water-free oil
- The purifier bowl is easily converted into clarifier bowl and vice versa Clarifier bowl —>no water removal
- To protect the bowl from excessive corrosion, a corrosion disc of aluminum is placed on the distributor base.

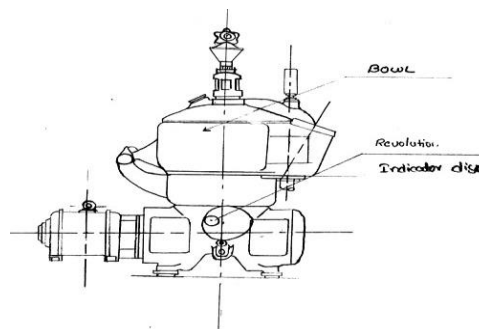

FIG: Separator

#### INITIAL CHECK-UP:

Before starting the reconditioned separator, check the following

- Bowl height
- Oil level in gear chamber
- Direction of rotation of bowl
- Starting time of bowl

- Bowl speed
- Smooth run of separator
- Tightness of suction line of dirty -oil pump
- Temperature of feed liquid
- Temperature of make-up water
- Adjustment of pre-set valve
- Proper functioning of bowl by watching oil and water discharge
- On purifier bowl
- On clarifier bowl

#### STARTING THE SEPERATOR WITH CLARIFIER BOWL

- Slacken back lock screws (see fig)
- Release brake(s) by turning handle(s) if in clock wise direction.
- Check if the bowl can be turned by hand and if the gear chamber is filled with a sufficient of oil (up to the upper third of the sight glass).
- Before the first start-up, fill a small amount of oil into suction pipe of gear pump to prevent pump from jamming.
- Close the hood and fasten it with handle nuts.
- Start the motor ; wait 5 to 8 minutes until the bowl has reached its rated speed has per name plate of the separator.
- Open shut-off valve in suction line of feed pump or in feed line to separator in order to feed dirty oil to heater. Close the valve as soon as oil appears at cylindrical sight glass.
- Switch on the oil heater and heat oil to separating temperature.
- Heat up the bowl by gradually feeding hot oil (open shut-off valve slightly only).

#### DO NOT FEED THE CLARIFIER BOWL WITH WATER:

- As soon as the bowl is warmed up, the shut of valve in the oil feed line to the separator has to be opened all the way.
- During the first start, adjust the pre-set valve which is fitted in the dirty oil feed line between shut off valve and separator to the appropriate hourly capacity (per separator with attached dirty oil feed pump prefer to figure). By turning the handle to the right, smaller capacities, by turning the handle to the left, greater capacity will be obtained. Number marks on threaded spindle facilitate resetting. If there is no change In feed material the valve need not be reset: the hourly capacity will then remind constant during the whole separation process. For processing a different type feed liquid the preset valve has to be re-adjusted. The through-out capacity of the separator depends upon the viscosity, temperature, density, degree of impurity, water content, and the desired degree of purity of the oil. For detailed information refer to the capacity chart for WESTFALIA oil separator which will be supplied on request.
- Watch outlets for oil and water.

#### REFERENCE DATA REGARDING SEPERATING TEMPERATURES AND MAKE UP WATER PERCENTAGES:

Bear in mind that optimum separating efficiency is achieved when oils of lowest viscosity are processed. For this reason the following separating temperatures are recommended.

Type of Oil	Separating Temperature	Make-up water
Gas Oil	Room Temperature	
Diesel oil, medium	Upto40°C	
Diesel oil. Heavy		
Heavy fuel oils (bunker oil) Of the following		

viscosity at 100°F:	80-90° C	1-3
500 s R I	90-95° C	drops/sec. max
1500 sRI	95-100° C	
3500 s R I		
Steam turbine lube oils	70-80° C .	
Oil sensitive to water, e.g. some types of oil		
with additives. HD oils	75-90° C	
Diesel engine lube oils, except for oils sensitive to water	75-90° C	2-5%

When treating emulsified oils, the separating temperature has to be increased. The temperature of the incoming process liquid is indicated by the thermometer fitted on the hood. The oil pre-heater has to be equipped with a thermostat.

#### HINTS FOR OPERATING THE CLARIFIER:

The clarifier bowl may only be fed with water free oils. Never feed clarifier bowl, neither before nor during operation.

#### STOPPING THE SEPARATOR:

1	Switch off the oil pre-heater; continue feeding oil for a
2	Stop dirty oil supply: close shut-off valve in oil supply line or in suction of feed pump
3	Stop warm water supply: close needle valve in make up water regulating device.
4	Switch off water pre-heater.
5	Switch off the motor.
6	Apply brakes by turning handles if counter clockwise. Wait until the bowl has come to a complete stop.
	DO NOT loosen any part of the separator before the bowl has stopped completely.
	Note that the bowl will not at rest before revolution indicator disc has ceased rotating.
	Holes in bowl bottom and frame drain permit self draining when machine is at rest. The solid impurities remain in the bowl.
7	Open oil drain of cock 28a and drain the oil which is contained in the feed channel of the hood. Then close drain cock again.
8	Clean the bowl.

#### CLEANING THE BOWL:

The bowl has to be cleaned after each shut down as soon as the sludge space is filled with solids. To reduce the down time as much as possible, each bowl is equipped with an exchangeable sludge liner which collects the

separated solids. By mean of hooks, the sludge liner can be easily lifted out of the bowl bottom. The bowl bottom remains in the separator frame.

Never wait until the settled solids reach the outer disc set rim. Generally, the disc set not be cleaned when the sludge liner is removed in time. When removing the sludge liner, be careful not to spill sludge between bowl bottom and frame rim.

#### RE-ADJUSTMENT OF BOWL HEIGHT:

The bowl height is adjusted at the factory before the separator is shipped. However, it must be checked for re-adjustment after re-assembly of the vertical gear parts and after exchanging the bowl.

Bear in mind that correct bowl height adjustment can only be made when the bowl is properly closed, i.e. when the "0" marks on bowl lock ring and bowl bottom are in line.

After unscrewing bottom bearing cap, adjust the bowl height by turning bottom bearing threaded piece until distance "h" between upper edge of frame rim and upper edge of bowl lock ring is 76mm on OTA I8 & 104mm on OTA 30.

#### TROUBLE SHOOTING:

Troubles	Causes	Remedies
1) The bowl does not come up to rated speed or takes too long to do so.	1) Brakes are on	Release brakes turning handles if clockwise.
	2) Bowl lock screws are in.	Slacken back bowl lock screws.
	3) Motor is incorrectly connected	Check motor connections.
	4) Friction surfaces of clutch shoes are oily.	Wipe dry friction surfaces. Do NOT use benzene, or Trichloroethylene
	5) Linings of clutch shoes are worn.	Replace clutch shoes
	6) Insufficient number of clutch shoes	Add one or two clutch shoes.
	7) Bowl is placed too high or too low.	Adjust to correct bowl height.
	8) Liquid or sludge has collected in the upper section of the frame resulting in slowing down of the bowl.	Check frame drain: liquid must be able to run out freely. Clean inside of upper section of frame.
	9) Clamp plates are not tight. Worn wheel slips on worn wheel shaft.	Tighten hexagonal head screws in worn wheel evenly and firmly. Tighten crosswise by single turns.
2) The bowl speed drops during operation.	1) Friction surfaces of clutch shoes are oily.	Wipe dry friction surfaces. Do NOT use benzene or trichloroethylene, or any other solvent.
	2) Motor speed drops during operation.	Check line voltage and inspect motor.
3) The bowl comes up to speed too quickly (in less than 4min) Motor pulls too high a starting current.	Too many clutch shoes are inserted. Note that driving effect of new clutch shoes will improve after several starts.	Reduce number of clutch shoes to 3 or 2. See that the shoes are equally distributed.



Troubles	Causes	Remedies
4) Uneven run of separator	1) The sediment has deposited unevenly in the bowl.	Clean the bowl
	2) Bowl is incorrectly assembled or parts of different bowls (if plant has several separators) have been interchanged.	Assemble bowl properly.
	3) Tension of disc stack has slackened	Make sure bowl lock ring is tightened properly. Check disc count. If necessary, add spare disc or blind spare disc.
	4) Bowl is damaged and therefore, out of balance.	Send bowl to factory or authorized factory repair shop. Do NOT attempt to make your own repairs. Never weld solder. Bowl is made of heat-treated steels.
5) Dirty oil pump does not suck in.	1) Dirty oil pump is defective.	Check shaft gaskets in pump. Inspect spill valve; if necessary re-adjust it.
	2) Suction lines are clogged or leaky	Clean or seal suction lines. Check bottom valve.
	3) Pre-strainer is clogged or leaky.	Clean pre-strainer. Replace gasket in cover.
6) Separator is getting tripped.	1)Over load 2)Dust accumulation 3)Power trip	<b>Project</b>

**PROBLEM:** At times this separator is getting tripped either due to over load or electrical power failure resulting in lot of oil going waste to trench if suction valve is not closed in time.

#### SUGGESTION:

As a remedy to such problem of oil going waste into trench, the following are the probable suggestions.

- To fix a 25micron filter in the suction line to avoid particles entry into the separator.
- To introduce a solenoid valve of proper size specification in the suction line of the separator. The quantity of discharge should be on par with the separator.

Even after introducing a suction line filter of proper micron filtration also there is a chance of getting tripped for separator later because dust is getting accumulated due to centrifugal force. Hence it is most economical useful to introduce the second suggestion that is solenoid valve.

As and when the separator is tripped the power to the solenoid also get tripped simultaneously where by the suction line gets closed by the solenoid operated valve. When power is there it gets energized valve gets opened to allow oil. The specification design parameter of the valve is shown in the figure

#### SPECIFICATIONS:

##### SOLENOID CONYROL VALVE:

VALVEDN50,P1N16,NO , 48V DC WITH MANUAL ENERGY CONTROL , VE2436N/HN-04801 , PRESSURE MAXIMIJN : 2MPA , DIAMETER : 50mm, Q<sub>max</sub> : 250lit/min

#### MATERIAL : BRASS

After fixing of solenoid valve oil wastage can be avoided as follows: As and when the separator is tripped the power to the solenoid also get off simultaneously where by the suction gets closed by the solenoid operator valve. When power is there it gets energized. => valve gets opened to allow oil.

#### REQUIREMENTS FOR IMPLEMENTATION:

- Solenoid valve with suitable discharge.
- 2 flanges similar to the flanges of the solenoid valve.
- Hack saw to cut the suction line.
- Spanners to open the suction line pipe.
- Electrodes for arc welding.

- Welding transformer.
- Electrical wire suitably.
- Safety appliances.

## OIL CONSERVATION

### Oil Conservation Guidelines:

These recommendations should be implemented whenever possible to maximize useful life and performance of hydraulic oils in industrial circulating systems:

**Temperature:**The hydraulic oil in the reservoir should be kept at ambient temperature or below 60°C (140°F) preferably, to minimize degradation by air oxidation. Increasing the size of reservoirs or adding coolers to small & hot systems are other methods for keeping system temperatures down.

**Particulate Contamination:**Contamination is a major enemy of hydraulic fluid systems. Typically, the original equipment manufacturer of hydraulic components will specify a target ISO cleanliness code to be maintained in a hydraulic fluid. Fluid contamination from dirt and wear metals can shorten the life of both the equipment and the hydraulic oil. Proper cleaning of a drained system including the reservoir prior to refilling can significantly extend life of the replacement oil.

**Water Contamination:**Keep water contamination to a minimum. Water in excess of 1000 ppm (0.1% water) in hydraulic oil can cause degradation and depletion of the performance additive system in the oil that was designed to provide protection to the hydraulic equipment. The result of this depletion will shorten the life of the oil.

**Restoring or maintaining system cleanliness:**When attempting to remove contaminants from a system, attention to the filters being used, the filter efficiency (Beta ratio), primary/secondary filter setup, filter bypass indicators, filter quality, and filter placement are all very important to accomplishing desired system cleanliness. If your oil is wet consider onsite dehydration service to restore the oil.

### Oil Analysis can be used for:

- Gear Boxes, Hydraulic Systems, Bearings, compressors,diesel Engines, gas and steam Turbines, Blowers/Fans, Incoming lubricants, stored lubricants etc.
- Oil Analysis for Condition Monitoring checks the Characteristics like:
- Color ,Kinematic viscosity, Viscosity Index
- TAN/TBN, Wear metals, water ,Flash point
- Demulsibility, Foaming, Particulate count.

### Oil conservation methods:

- Contamination
- Evaporation
- Filtration
- Leakages

### Maintenance:

Three simple maintenance procedures have the greatest effect on hydraulic system performance, efficiency and life.

1. Maintaining a clean sufficient quantity of hydraulic fluid of the proper type and viscosity.
2. Changing filters and cleaning strainers.
3. Keeping all connections tight, but not to the point of distortion, so that air is excluded from the system.

## CONTAMINATION CONTROL

### Preventive Measures:

The measures to conserve the oil:

### For Storage Drums:

- Store in cool, dry location.
- Ensure that closures fully seal in the fluid.
- Wipe away any dirt and moisture from around the closure before loosening and emptying.
- Use a portable filtration and transfer unit for emptying and refilling.

**For Storage Tanks:**

- Install in cool, dry location.
- Ensure that all covers and stop valves effectively seal in the fluid.
- Keep filling lines clean; cap ends when not in use.
- Use a portable filtration unit for filling and emptying.

**For Hydraulic Systems:**

- Provide fluid filter(s) in location(s) that assure the required protection.
- The ideal steady-state flow conditions through an off-line filter make this a must for most applications.
- Whenever possible, use filters having element condition indicators.
- Vented systems must be fitted with an air breather appropriate to the environment(s) in which the machine is to be operated and the requirements of the system.
- Fit strainers to pump inlet lines if there is risk of large contaminant particles (i.e. string, rag, screws, etc.) entering the lines.
- Prevent air entering the system, particularly through pump inlet lines. Ensure air-tight joints in any sub-atmospheric zone or pump inlet lines. also make sure that those lines and all return and drain lines terminate below the minimum fluid level in the reservoir; pump inlet lines should be sufficiently below to prevent air entering through a vortex at low fluid levels.
- Pre-clean pipes and reservoir immediately before installation. Cap any ends that cannot immediately be connected to mating components (e.g. between shifts).

**For Hydraulic Systems:**

- Remove protective caps only just before connecting mating components.
- Use a portable filtration and transfer unit to fill the reservoir system.
- Flush new systems, and those that have undergone major repairs, before starting up. Temporarily remove actuators and replace with flushing manifolds or valves. Servo valves and similar high precision units should also be replaced with flushing manifolds or valves for flushing operations. Make sure that actuators are clean internally before Connecting to the system.
- Make sure that air breathers and reservoir covers are at all times properly installed and tightly secured.
- Stop any leakage of water into the system from coolers or other sources. Make a leak- tight repair.
- By planned maintenance, ensure that clean filter elements are applied (or metallic elements cleaned when appropriate) when indicators or visual inspection shows this to be necessary.
- Take fluid samples periodically and analyze to determine whether effects of particle contaminant, heat, water and air indicate need for more control of those factors or replacement of the fluid.
- Whenever the reservoir is emptied, clean it out thoroughly and remove all residual contaminant. If necessary, restore protective paint or other finishes. On completion, cap all openings unless the system is to be refilled immediately.

**Contamination control & Purification:**

The contamination control and purification of the lubricants is being carried out by using equipments like Electrostatic Liquid Cleaner (ELC), Low Vacuum Dehydrator (LVDH) and Centrifuges.

**ELC Machine:Electrostatic Liquid Cleaner:**

- It works on the principle of Electrostatics to separate and collect fluid contaminants. Electrostatic force applies to all particles and they migrate to positive or negative electrodes.
- Maximum collection occurs at the edges of the collectors where the intensity of the electric field is stronger. In ELC electric force is created by a transformer which charges two sets of SS electrodes one positive and one negative.
- Suspended particles up to 0.01 microns can be removed from the oil by using this machine. It is

connected to the tank of the hydraulic system and allowed to run continuously. There are 44 no's of ELC are there in VSP.

#### ELCTROSTATIC LIQUID CLEANER (ELC):



FIG. ELC

#### LEAKAGES: Leakage control

##### Cost of Leakage:

Concern for safety at work and the rapidly increasing cost of oil makes industry sensitive to leakage.

- Leakage creates safety hazards, wastes costly oil, increases machine down-time, decreases production rates, generates product spoilage and increases replacement parts inventory.
- The cost of effective leakage control is minor when compared to the long term costs of leakage.

##### Leak-Free Design:

Hydraulic systems do not need to leak. Today's designer must create a more leak resistant system, where static seal leakage should not occur and dynamic seal leakage will be controlled. Before presenting some design practices proved effective in stopping leaks, we should consider the sources of most leaks.

##### Cause Of Leaks:

Almost all hydraulic system leaks occurring after extended service result from three conditions:

- Loosening of fittings and connectors by shock and vibration.
- Wear of dynamic seals and mating parts especially in hydraulic cylinders.
- Deterioration of the elastomer because of elevated fluid temperatures or an incompatibility with the hydraulic fluid.

##### Combatting Shock And Vibration:

Many things can be done to minimize leakage from loose fittings and connectors subject to shock and vibration:

- Support all pipe lines with damped mountings to absorb both shock and vibration.
- Reduce shock with low-shock valves or accumulators.
- Use pressure controls with low override and strategically placed to protect all parts of the system.
- Use a minimum number of fittings and connectors. Use welded joints wherever practical.
- Use parallel thread connectors, tees and elbows in place of tapered pipe threads.
- Use manifolds instead of individual lines wherever possible.
- Specify proper bolt and plug torques for expected peak pressures to prevent surface separation and static seal nibbling.
- Stress good workmanship to avoid poorly assembled fittings and connectors.

### **Preventing Seal Deterioration:**

Premature deterioration of the seal can result from other factors. A primary factor is excessive fluid temperature.

The following brief seal materials may be helpful.

- Nitrile (Buna N) is the most widely used and best all around elastomer for petroleum (mineral) oils, fuel and fire-resistant fluids – with the exception of phosphate esters.
- Fluoroelastomer (Viton or Fluorel) costs more than Nitrile, can be used instead of Nitrile but has the added advantage of longer life when fluid temperatures consistently run above 150 F. It can be used with phosphate ester fluids (except Skydrol).
- Polyurethane shows extrusion and abrasion resistance superior to Nitrile in petroleum oils, fuel and silicate esters, but deteriorates if contaminated with hot water. Refer to “Stop Leaks” bulletin 394 for more comprehensive coverage of leakage control.

### **OIL RECLAMATION PROCESS FLOW CHART:**

**There is various conservation measures are to being taken:**

1. Extending the life of oil through Centrifuging, condition monitoring and on site checking/correction.
2. Contamination control through latest technology like ELCs, LVDH & Filters.
3. Creating awareness about the conservation of lubricants.
4. Minimizing the losses by using high quality hydraulic & lubricating equipments and spares like oil seals, O rings, hoses, pipe fittings, and pneumatic pumps.
5. Adopting used oil management which also reduces the effect on the environment.
6. Even though taking a lot of measures still consumption is not decreasing though it is constant and lot of gap between consumption and return of used oil.

### **Points to be followed to extend the life of the oil:**

- Maximum care to be taken while filling oil. Cleanliness of the drum containers to be checked. As far as possible manual filling should be avoided and use pump and filters.
- Close all the openings on the tanks with bolts and nuts with rubber beadings. Avoid temporary openings for ease of inspection and oil filling.
- Clean the filters regularly & replace the air breathers periodically.
- Clean the tank top/components periodically.
- Ensure coolers and heaters are working properly and maintain required oil temperature.
- Maintain correct oil levels and never run with very low levels.
- Observe the color of the oil periodically.
- Run the centrifuges whenever water or scale enters into the oil.
- Collect the oil samples and test the oil periodically and take the necessary corrective actions based on the test results.
- Remove the accumulated free water from the drains periodically.
- Change the damaged oil seals immediately to avoid the oil leakages.
- Use right grade of oil of right quantity at right application in right way.
- Collect the drained oil in cleaned container return to the ORU for reclamation.
- Create awareness among the people who handle the oil and greases and inspects the system.

### **CONCLUSION**

- Thus with the implementation of our mini project, there is reduction in oil wastage and increase in efficiency of the separator and thereby increasing the effectiveness of the hydraulic system.
- To conclude, our work also emphasizes on the importance of oil conservation and the ways to implement the same as the oil is scarce, costly, non-renewable source of energy
- Within the given time that is span of 2 weeks we couldn't able to study only small part of Vishaka Steel Plant in MMSM department (Finishing of Steels through Hydraulics)

### **BIBLIOGRAPHY**

- Rk. Rajput, a text book of fluid mechanics, s. chand,2008

http: // [www.ijesrt.com](http://www.ijesrt.com)

© *International Journal of Engineering Sciences & Research Technology*

- [www.nptel.ac.in/courses/112106175/module%201/lecture](http://www.nptel.ac.in/courses/112106175/module%201/lecture)
- [en.wikipedia.org/wiki/hydraulic\\_accumulator](http://en.wikipedia.org/wiki/hydraulic_accumulator)
- majumdar,oil hydraulic system:principles and maintainence,tata Mc Graw-Hill education,2002